

# Studie einer Rollbremse

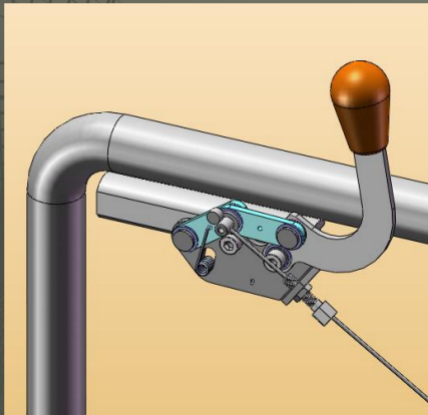

Sitzrohr

für linke  
Hand

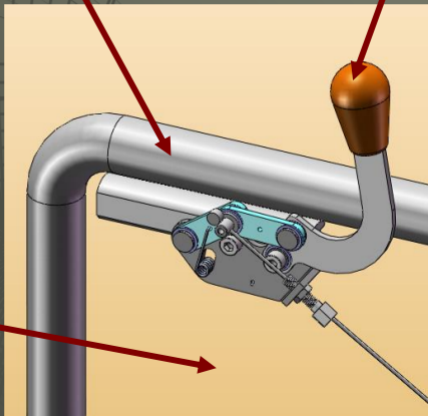

Rad

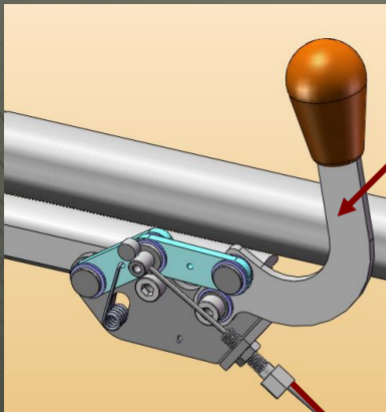

offen

Bremse in  
der Nabe

# Kriterien der Konstruktion:

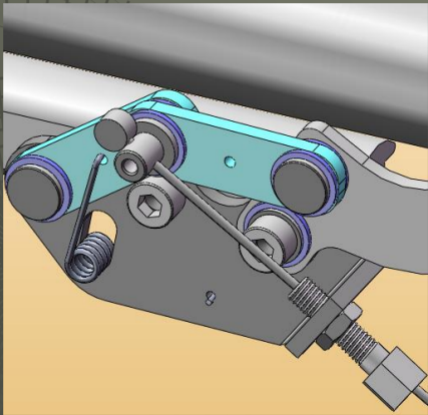

möglichst viele  
Normteile oder Kaufteile

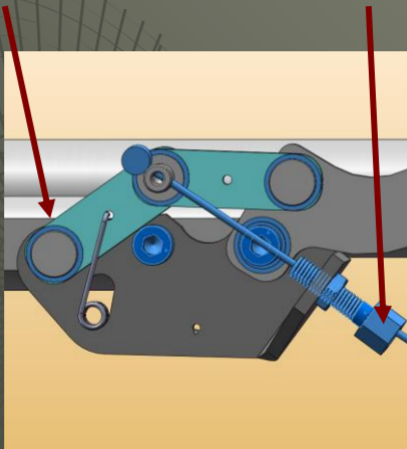

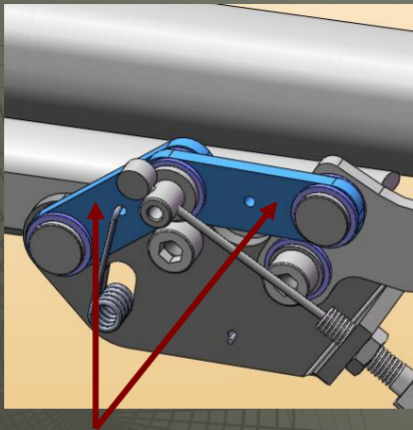

Gleichteile und  
Symmetrie

# Doppelfunktionen Schraube als Anschlag

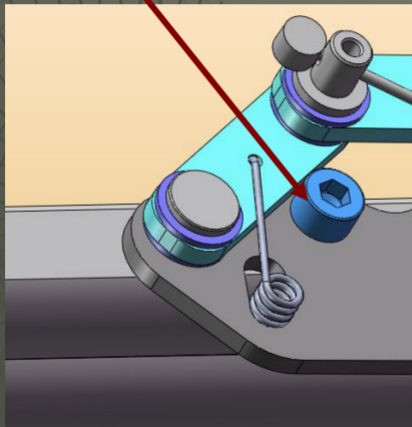

# herkömmliche Feder

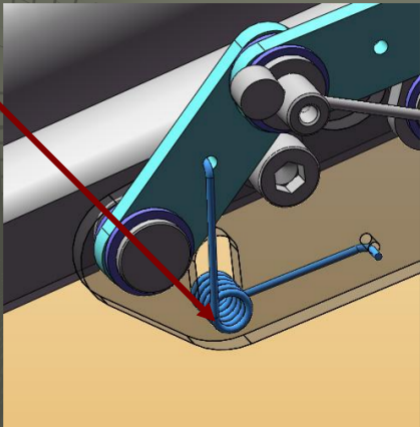

# Bremsen

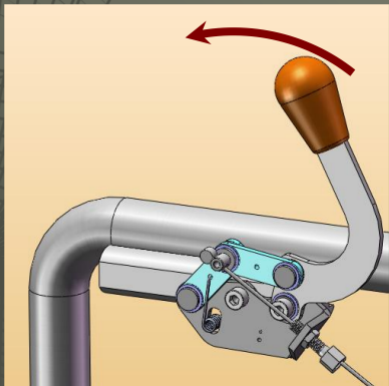

# Bremsen

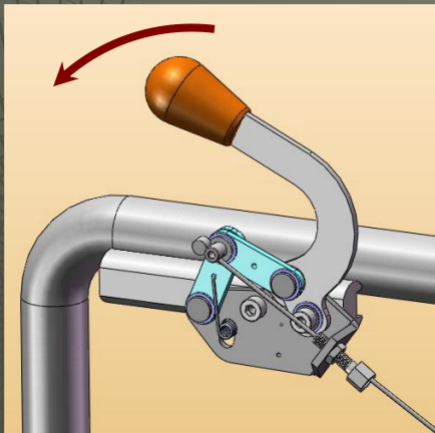

# Bremsen

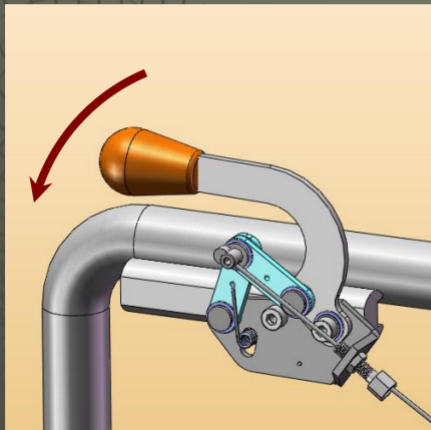

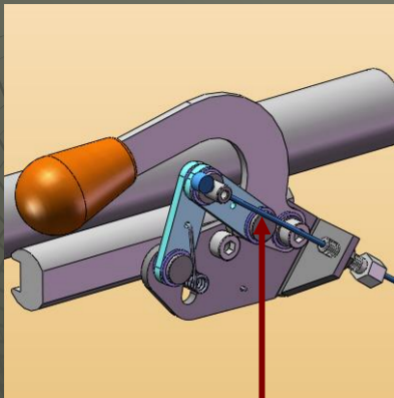

Bremse arretiert